

4

3

2

1

PARTS LIST

ITEM	QTY	PART NUMBER	DESCRIPTION
1	1	RA-40286	HUB, GEAR
2	1	RA-40086	GEAR, HELICAL, 50 TEETH
3	1	RA-40301	MOUNT, FORK
4	1	RA-40302	FORK, PATCH PHASING
5	1	RA-10033	GREASE FITTING
6	1	RA-40303	ADJUSTMENT RING
7	1	MAR-008.00022	SOCKET HEAD CAP SCREW, 5/16-18
8	3	MAR-008.00071	SOCKET HEAD CAP SCREW, 1/4-20
9	1	MAR-010.00129	RETAINING RING
10	1	MAR-010.00130	RETAINING RING

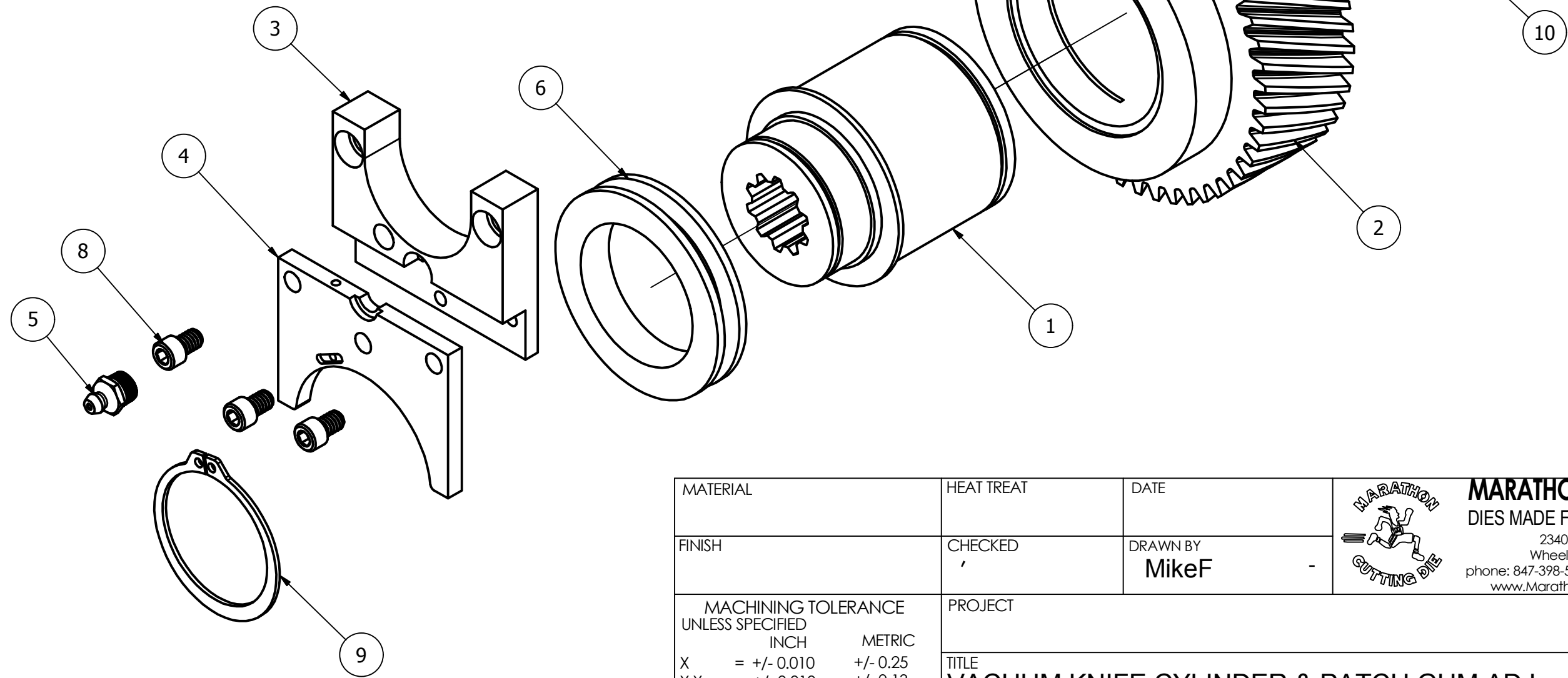

MATERIAL	HEAT TREAT	DATE	 <b>MARATHON CUTTING DIE</b> DIES MADE FOR THE LONG RUN 2340 Foster Ave Wheeling, IL 60090 phone: 847-398-5165 / fax: 847-398-5195 www.MarathonCuttingDie.com
FINISH	CHECKED	DRAWN BY <b>MikeF</b>	
MACHINING TOLERANCE UNLESS SPECIFIED INCH      METRIC X      = +/- 0.010    +/- 0.25 X.X     = +/- 0.010    +/- 0.13 X.XX    = +/- 0.010    +/- 0.08 X.XXX   = +/- 0.005    +/- 0.02 X.XXXX = +/- 0.0005 ANG.   = +/- 0.5 DEG		PROJECT	
TITLE <b>VACUUM KNIFE CYLINDER &amp; PATCH GUM ADJ.</b>			QTY.
SCALE	REV	SIZE <b>B</b>	DWG. NO. <b>SA-RA-4026</b>
			SHEET <b>1 of 1</b>